

---

---

**REPORT No. 333**

**FULL-SCALE TURNING CHARACTERISTICS OF  
THE U. S. S. LOS ANGELES**

**By F. L. THOMPSON**  
**Langley Memorial Aeronautical Laboratory**



## REPORT No. 333

### FULL-SCALE TURNING CHARACTERISTICS OF THE U. S. S. LOS ANGELES

By F. L. THOMPSON

#### SUMMARY

*This paper presents a description of the method employed and results obtained in full-scale turning trials on the rigid airship U. S. S. "Los Angeles." This investigation was requested by the Bureau of Aeronautics, Navy Department, and was carried out in conjunction with pressure distribution and stress investigations. The pressure and turning investigations were conducted by representatives of the National Advisory Committee for Aeronautics and the stress investigation by the Bureau of Aeronautics.*

*The results of this investigation are not sufficiently comprehensive to permit definite conclusions as to the variation of turning characteristics with changes in speed and rudder angle. They indicate, however, that the turning radius compares favorably with that for other large airships, that the radius is independent of the speed, that the position of the point of zero yaw is nearly independent of the rudder angle and air speed, and that a theoretical relation between radius and angle of yaw in a turn gives a close approximation to actuality. The method of determining turning characteristics by recording instruments aboard the airship appears to be satisfactory, with the exception that a better method of determining the small angular velocities of airships should be devised.*

#### INTRODUCTION

The turning characteristics of a number of full-size airships have been determined at various times and places, by divers methods, and with varying degrees of success. The data obtained in such trials are of interest because they are a measure of maneuverability and forces active in a turn, neither of which can be measured in wind-tunnel tests on airship models. Accurate and consistent data, however, are scarce, and any new information is therefore of considerable interest.

This paper presents the results of turning trials on the rigid airship U. S. S. *Los Angeles*. These trials constitute one phase of a joint investigation requested by the Bureau of Aeronautics, Navy Department, to determine structural stress, distribution of pressures over the hull and tail surfaces, and turning characteristics of the airship. The stress investigation was conducted by the Bureau of Aeronautics, and the pressure and turning investigations were conducted by the National Advisory Committee for Aeronautics, all during the same flights from the hangar at Lakehurst, N. J. The stress and pressure investigations have been previously reported. (Reference 1.) Pressures were measured during some of the turning trials, and simultaneous pressure and turning data were obtained in a few cases.

The results obtained and a description of the method employed are contained in this paper. In addition, there are included a comparison of the results with a theoretical relation between radius and angle of yaw in a turn and suggestions regarding a method for future investigations of this sort. The observed data are shown by curves of air speed, yaw, rudder angle, angular displacement, and angular velocity, plotted on a time base. The turning characteristics computed from values taken from these curves are given in tabular form. Complete data were obtained during only a few runs and are therefore insufficient to fully define the turning characteristics with respect to their variation with speed and rudder angle.

## METHOD AND APPARATUS

An attempt was made to determine the turning characteristics of the *Los Angeles* by two independent methods simultaneously. In accordance with this plan, air speed, yaw, angular velocity, and rudder position were recorded by instruments aboard the airship during each turn, while a record of the flight path was obtained with a camera obscura on the ground. Satisfactory data from either source are sufficient to define the turning characteristics, providing the camera-obscura records of the flight paths are corrected by the proper wind vectors. It was necessary, therefore, to obtain measurements of the wind velocity and direction at the time of each turn.

All the necessary data were obtained during the flights, but it was found impossible to obtain consistent values for the turning characteristics from the data given by either one of these methods alone. The angular velocities given by the turnmeter records and the wind vectors given by aerological observations were found to be unsatisfactory. The turnmeter, originally designed to record the comparatively high angular velocities of airplanes, failed to give sufficiently accurate records of the small angular velocities of the airship, and the wind vectors were either too inaccurate or inadequate to be used in finding the true flight path.

The angular displacement of the airship, however, is not affected by the wind, and it was possible, therefore, to determine the angular displacements accurately from the camera-obscura records. These data, combined with air speed, yaw, and rudder position records obtained aboard the airship, were used to define the turning characteristics.

The *Los Angeles* is a rigid airship, having the following characteristics: Length, 656 feet; maximum diameter, 90.7 feet; air volume, 2,760,000 cubic feet; horsepower, 2,000; number of engines, 5.

The complete instrument installation aboard the airship has been previously described in the report on the pressure distribution investigation. (Reference 1.) The only parts of this installation of interest in the turning investigation are the yaw observer, air-speed recorder, control position recorder, and the inclinometer. A description of these instruments is repeated.

The yaw observer consists of a motor-driven motion-picture camera focused on a "yaw bomb" suspended on a cable from the airship. The "yaw bomb" is a streamlined body fitted with fins that align it with the direction of the relative wind. The camera was mounted so that it could be rotated about the lateral and longitudinal axes, but not about the vertical axis. One edge of the rectangular picture frame of the camera was used as a reference line and was aligned parallel to the longitudinal axis of the airship. Since the camera could not be rotated about its vertical axis, this reference line always lay in a plane parallel to the airship's longitudinal axis. This alignment was later checked in flight by photographs of the airship's shadow obtained while flying over water with the sun nearly overhead, and was found to be in error by approximately 1°. With the camera pointing directly downward the angle of yaw is given directly by the angle between the "yaw bomb" image and the reference edge of the picture, subject to the correction for misalignment. When the camera is tilted, however, the apparent angle is greater than the true angle by an amount which depends on the angle of tilt and the location of the image in the picture. During the tests the yaw camera was sighted directly on the "yaw bomb" so that its image would always appear in the center of the picture. Consequently, the camera was tilted in pitch by amounts which varied with the air speed. These angles of tilt ranged from 7½° to 10¼°, and the corresponding corrections to the apparent yaw angles varied from 4.5 to 6.5 per cent. A sample record is shown in Figure 1. The camera was driven at a speed of 18 images per minute. The "yaw bomb" was suspended 360 feet abaft the nose of the airship by a 75-foot cable. This distance includes an estimate of 12 feet to allow for rearward displacement due to the resistance of the "yaw bomb" and suspension cable.

An N. A. C. A. recording air-speed meter (Reference 2) connected to a Pitot-static tube suspended from the airship by a cable 35 feet long was used to measure air speed. The resistance of the necessarily large cable was considerable and accounts for an estimated rearward displacement of 15 feet. The total distance of the Pitot-static tube abaft the nose of the airship

was 265 feet. True air speed was obtained by correcting the records for the density at which the flights were made.

An N. A. C. A. control-position recorder (Reference 3) was used to record rudder and elevator positions. In this instrument a mirror is mechanically connected to the control cable through a suitable reduction mechanism, and motion of the mirror is recorded photographically. The recorder was placed inside the lower fin and was connected to the control cables as near to the controls as possible to avoid inaccuracies due to stretch or slack in the cables.

An N. A. C. A. recording inclinometer, which records on photographic film the movement of an oil-damped pendulum, was used to record inclination of the longitudinal axis of the airship. The records obtained with this instrument and also the elevator position records were of use in determining whether or not the airship was reasonably level and steady during turns.

An N. A. C. A. chronometric timer (Reference 4) was used to synchronize the above records at 16-second intervals.

A camera obscura was used to record the path of the airship during turns. (Reference 5.) It is essentially a large camera, which permits a person to remain in the darkened chamber and to observe the image of an external object which is projected on a suitable surface within the



FIGURE 1.—Portion of a yaw-observer record

chamber by a lens in the camera aperture. In these tests a wide-angle lens was used to project the airship's image on a 30 by 30 inch photographic film. The film was completely covered by a movable light-proof screen in which a small motor-driven shutter was mounted, as described in Reference 5. The shutter opened at regular intervals and exposed a film area just large enough to contain the airship's image. By following the moving image with the shutter a photographic record of the position and attitude of the airship at 8-second intervals was obtained during such part of each turn as was made in the camera field. A sample record is shown in Figure 2.

In connection with the camera-obscura records it was necessary to determine the direction and magnitude of the wind at the altitude of flight. These data were obtained from observations made at the local Naval Aerological Station at  $\frac{1}{2}$ -hour intervals. The usual pilot-balloon method of observation was used.

Synchronization of the camera-obscura records with those taken aboard the airship was obtained by the use of radio signals and two stop watches which were synchronized before the airship left the ground. One watch was kept at the camera and the other was carried aboard the airship. Communication between the airship and camera-obscura station was established by radio before making a run, and a signal was given when records were started in the airship. The start and stop times for the records at both places were recorded and were used later to determine what part of each turn was recorded simultaneously by instruments and camera obscura.

The method of determining the true flight path and turning characteristics from camera-obscura records is fully described in Reference 5. The true path is found by adding the proper wind vectors to the recorded path. The center of the corrected flight path, the radius of turn, and the angle of yaw at any point along the airship's axis are found by geometrical methods and measurements.

When the wind has an appreciable magnitude the accuracy of the determination of the true flight path is chiefly dependent upon the accuracy with which the wind vectors are determined. Not only is the magnitude important, but the direction also is extremely important. Both of these items must be accurately measured if the yaw and radius of turn are to be accurately determined. The wind vectors given by the aerological data for the days on which turning trials were made showed wide variations both in direction and magnitude at different

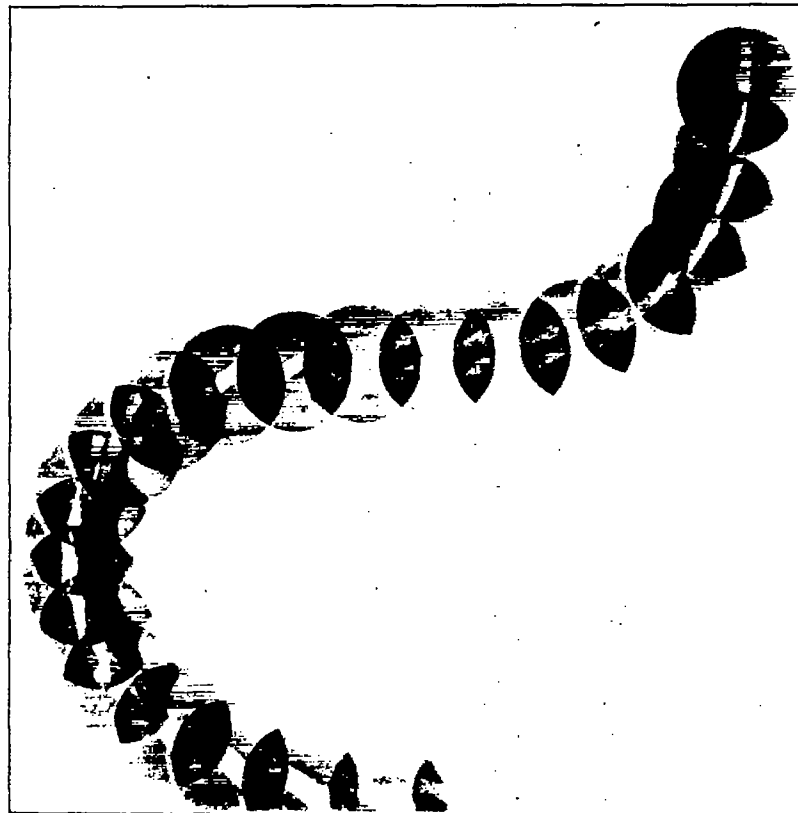

FIGURE 2.—Camera obscura record of a reversal

times and altitudes. In attempting to use these vectors it was found that no consistent results could be obtained, and this method of determining the turning characteristics had to be abandoned. However, the attitude of the airship is not affected by the wind, and it was found possible to measure the angular displacements with good accuracy and to derive angular velocities in steady turns with satisfactory accuracy.

By combining the angular velocities determined by the camera-obscura method with the yaw, air speed, and rudder angle records taken aboard the airship the turning characteristics were determined. Complete data were obtained during only a few turns, so that the available information is insufficient to definitely establish the effect of variations in rudder angles and air speed. The synchronization of camera-obscura records with those taken aboard the airship showed some obvious inconsistencies, which were corrected by judgment based on a proper consideration of the factors affecting the angular displacement and velocity. The resulting synchronization is satisfactory for conditions of steady turning.

## PRECISION OF RESULTS

The air-speed records show some variations that were apparently caused by oscillations of the air-speed head, or, in a few cases, to errors in plotting. The possibility of errors in plotting is due to difficulty in properly locating the time intervals in a few cases where the records were crowded due to slippage of the film-drive mechanism. The air speeds are represented by faired curves drawn to avoid these variations. The accuracy of the air-speed recorder is within  $\pm 1$  per cent. The accuracy with which the true air speed of the airship is represented by the faired curves is also considered to be within  $\pm 1$  per cent, with the exception that in run 5C, the error may be  $\pm 2$  per cent.

The individual yaw readings are subject to an error of  $\pm \frac{1}{4}^\circ$  in the measurements of the photographed angles. In some cases they are also subject to a larger error, which is indicated by the rapid fluctuation of observed angles and is attributed to oscillations of the "yaw bomb." It is believed, however, that the mean curves drawn through the observed points eliminate the possibility of error from these causes to within  $\pm 0.2^\circ$  for conditions of steady turning. There also exists the possibility of a slight constant error of  $\pm 0.1^\circ$ , due to error in determining the small angle between the yaw camera reference line and the longitudinal axis of the airship. The accuracy of the curves and tabulated values of observed yaw for conditions of steady turning is therefore considered to be within  $\pm 0.3^\circ$ .

Angular velocities were determined by the graphical differentiation of angular displacement curves. The angular displacement curves were drawn through points obtained from measurements of the attitude of the ship at 8-second intervals, as recorded by the camera obscura. These curves are considered to be accurate within  $\pm 1$  per cent. They were drawn to a large scale and differentiated with respect to time. For steady turns the changes in slope are slight and the angular velocities obtained are probably accurate to within  $\pm 2$  per cent.

The rudder position record is considered to be accurate to within  $\pm \frac{1}{4}^\circ$ .

From a consideration of the accuracies stated above it follows that calculations of  $R$  and  $R\beta$ , discussed later, may be in error by  $\pm 3$  per cent and  $\pm 7$  per cent, respectively. The average values for each run, however, are more accurate.

## RESULTS

The observed data are shown by curves, Figures 3 to 7, in which air speed, yaw, rudder angle, angular displacement, and derived angular velocity are plotted against time. The camera-obscura records of angular displacements are noticeably shorter than the instrument records obtained aboard the airship, because the airship was always out of the camera-obscura field at the start and end of each maneuver. Consequently, the angular displacements represented by the curve for each run are measured from the start of the camera-obscura record and not from the start of the maneuver. This does not affect the determination of angular velocity, however, since the slope is not changed by shifting the zero reference.

Time intervals are indicated on the time scales of the curves, so that pressure data which are given in Reference 1 for certain time intervals may be referred to these curves. It should be remembered, however, that the synchronization of camera-obscura records with the records of air speed, yaw, and rudder angle may be slightly in error. Therefore it is likely that a particular value of angular velocity does not correspond to the instant indicated by the time scale within possibly two or three seconds. This has no serious effect on the accuracy of values taken from the curves during steady maneuvers, but would lead to questionable values of angular velocities where the slope of this curve is large. For this reason simultaneous values should not be taken from the curves during periods of pronounced angular acceleration. The curves of Figure 7 can not be used, therefore, except to show the approximate relation between the variations in air speed, yaw, and angular velocity in a hard reversal at high speed, since it does not include a record of the angular velocity during steady turning, either right or left.

The geometry of a turn is illustrated by Figure 8.

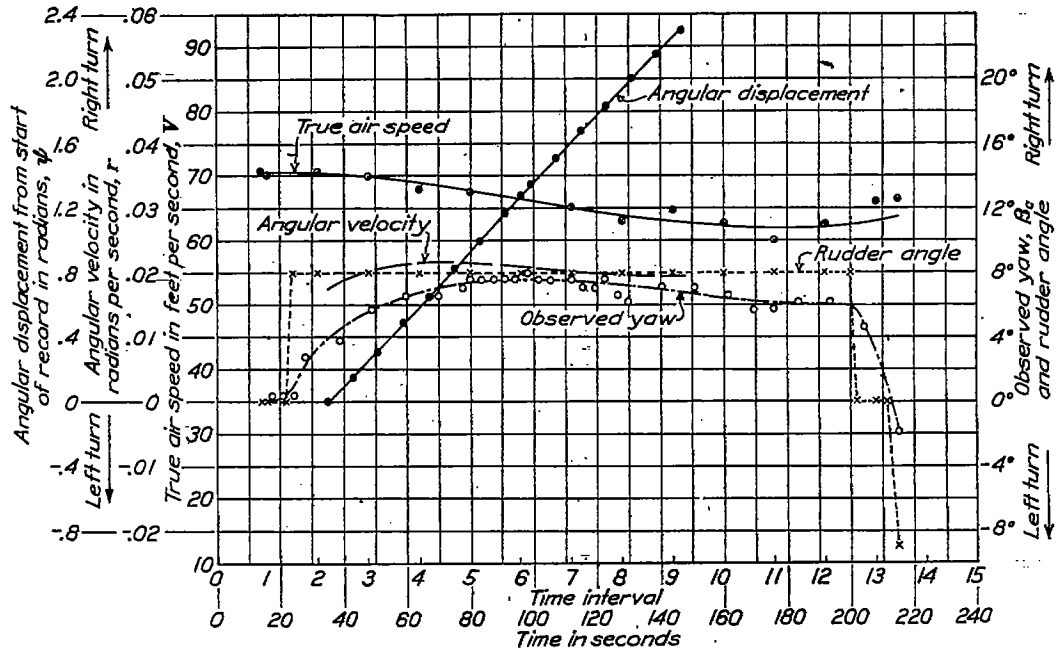

FIGURE 3.—Run No. 40. Right turn. Altitude referred to standard atmosphere=3,080 feet

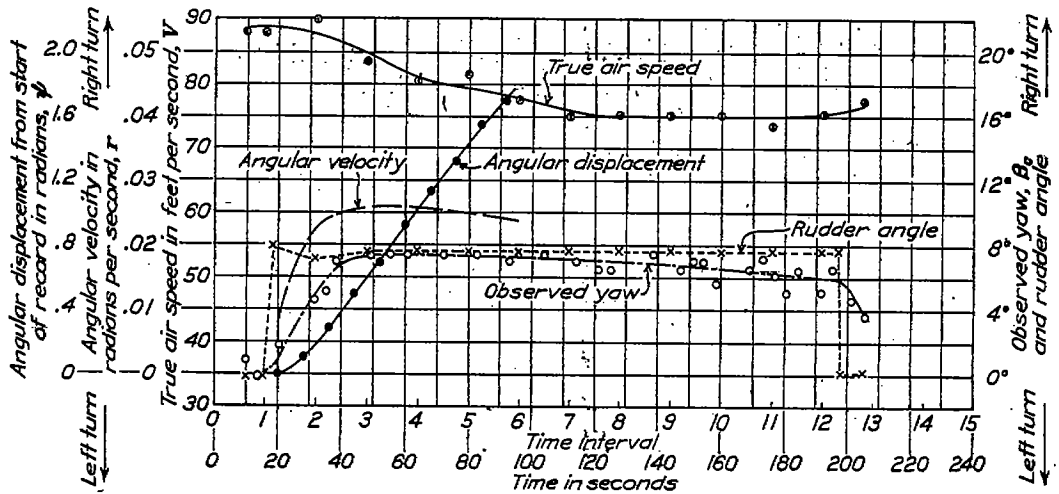

FIGURE 4.—Run No. 50. Right turn. Altitude referred to standard atmosphere=3,080 feet

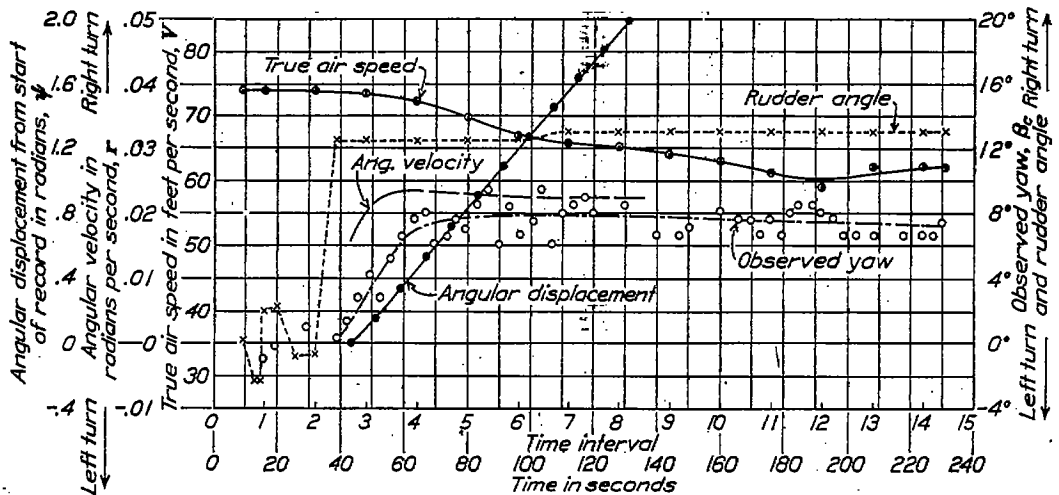

FIGURE 5.—Run No. 18D. Right turn. Altitude referred to standard atmosphere=3,030 feet

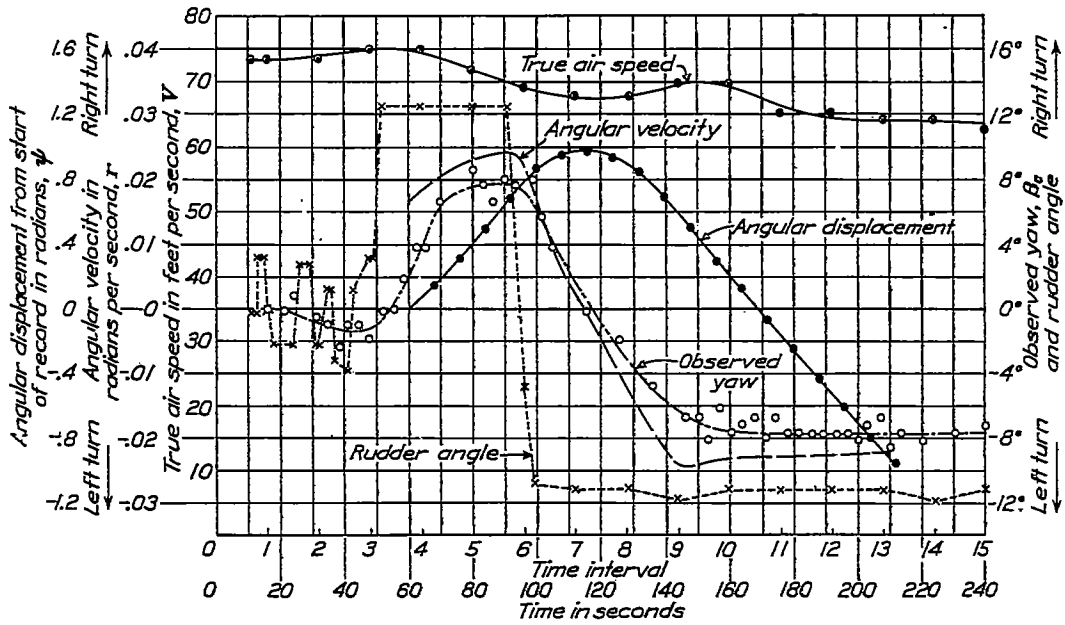

FIGURE 6.—Run No. 14D. Reversal—right to left. Altitude referred to standard atmosphere=8,030 feet

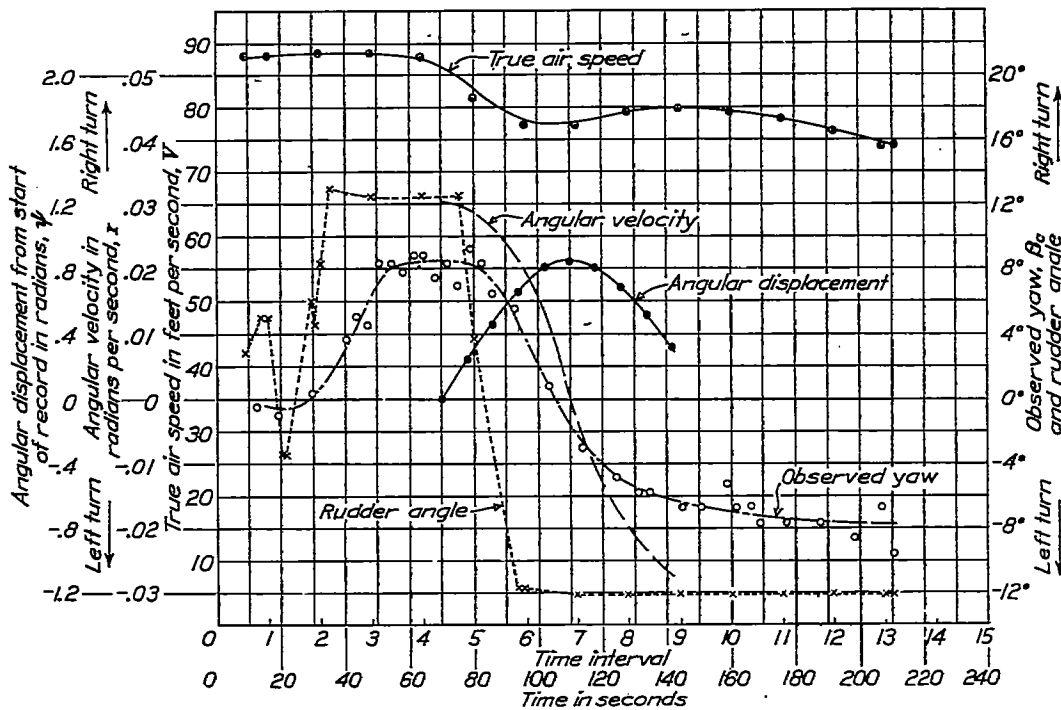

FIGURE 7.—Run No. 17D. Reversal—right to left. Altitude referred to standard atmosphere=8,030 feet

The symbols used are as follows:

- A*—Location of the point of zero yaw.  
*B*—Location of the air-speed recorder.  
*C*—Location of the yaw observer.  
*G*—Location of the *c. g.* of the airship.  
*N*—Location of the nose of the airship.  
*V*—True air speed tangential to the path of the *c. g.*  
*V<sub>B</sub>* and *V<sub>C</sub>*—True air speed tangential to the paths of the points indicated by the subscripts.  
*r*—Angular velocity of the airship about the center of turn.  
 $\beta$ —Angle of yaw at the *c. g.*  
 $\beta_c$ —Angle of yaw observed at *C*.  
*R*—Radius of the path of the *c. g.*  
*R<sub>A</sub>*, *R<sub>B</sub>*, and *R<sub>C</sub>*—Radii of the paths of the points indicated by the subscripts.  
*L*—Length of the airship.  
*Rβ*—A linear quantity equal to length *GA* of Figure 8, which is the distance from the *c. g.* to the point of zero yaw.  
*K*—Turning coefficient defined as  $\frac{2R}{L}$ .  
*a*—Distance from the *c. g.* to the center of pressure on the vertical tail surfaces.  
*k<sub>2</sub>*—Transverse coefficient of additional mass of the airship.  
*k<sub>1</sub>*—Longitudinal coefficient of additional mass of the airship.

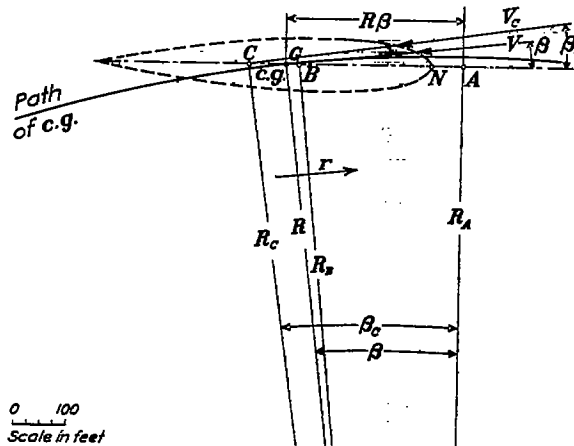

FIGURE 8.—Diagram of the *Los Angeles* in a turn

The turning characteristics were computed from values taken from the curves of Figures 3 to 6 at 10-second intervals during conditions of steady turning. The observed and computed values are given in Table I. An explanation of the method of computing referred to Figure 8 follows.

The observed data give the air speed at point *B* (*V<sub>B</sub>*), the yaw at point *C* ( $\beta_c$ ), and the angular velocity (*r*). From these data the air speed at the *c. g.* (*V*), the yaw at the *c. g.* ( $\beta$ ), the radius of the path of the *c. g.* (*R*), the distance from the *c. g.* to the point of zero yaw (*Rβ*), and the distance from the nose of the airship to the point of zero yaw (*AN*) are obtained.

There is a slight difference between the radii *R<sub>A</sub>* and *R<sub>C</sub>*, but the difference between *R<sub>B</sub>* and *R<sub>C</sub>* is only 10 or 15 feet, and therefore may be neglected, since  $R \approx 3,000$  feet.

It follows, therefore, that

$$V = V_B$$

and

$$R = \frac{V_B}{r}$$

For angles less than  $10^\circ$  it may be considered that

$$\sin \beta = \beta$$

and, therefore, the distance  $R \sin \beta = R\beta$ .

From this it follows that

$$R\beta = R\beta_C - GC$$

and

$$\beta = \frac{R\beta_C - GC}{R} \text{ (in radians)}$$

also

$$AN = R\beta - GN$$

which gives positive values of  $AN$  when  $A$  is forward of the nose of the airship.

The distances from  $B$ ,  $G$ , and  $C$  to the nose ( $N$ ), Figure 8, are as follows:

$$\begin{aligned} BN &= 265 \text{ feet} \\ GN &= 289 \text{ feet} \\ CN &= 360 \text{ feet and} \\ GC &= 71 \text{ feet.} \end{aligned}$$

The data show the order of magnitude of the turning characteristics, but are too meager to be used in determining definitely the variations of these characteristics with changes in speed and rudder angle. The turning coefficients agree roughly with those given for the British airships *R. 33* and *R. 38* (References 6 and 7) and indicate much better maneuverability than those given for the *R. 29* (Reference 8). The radius of turn shows no variation for two similar turns made at different speeds, which agrees with the results given in Reference 8. The length,  $R\beta$ , appears to be independent of the rudder angle and nearly independent of the speed, which tends to substantiate the constancy of  $R\beta$  indicated by previous tests. (Reference 9.)

A comparison of the results is made with a relation between radius and angle of yaw given by Burgess in Reference 10, derived from the first term of Munk's equation for forces in a turn, Reference 11. The reasoning used in the derivation of this formula is that the transverse fin force equals the centrifugal force in a turn, and the moment of this force about the *c. g.* equals the yawing moment on the hull, expressed by the first term of Munk's equation.

Burgess's equation is

$$\sin 2\beta = \frac{2a}{R(k_2 - k_1)}$$

where  $a$  is the distance from the *c. g.* to the center of pressure on the tail,  $k_2$  is the transverse coefficient of additional mass of the airship, and  $k_1$  is the longitudinal coefficient of additional mass.

Lamb's coefficients of additional mass for ellipsoids of various length-diameter ratios are given in References 10 and 11. The equivalent ellipsoid of the airship is given by

$$\frac{\text{length}}{\text{diameter}} \text{ (of ellipsoid)} = \sqrt{\frac{\pi(\text{length})^3}{6 \text{ volume}}} \text{ (of airship)} \text{ (Reference 10)}$$

For the *Los Angeles*  $k_2 - k_1 = 0.9$ , and  $a = 275$  feet. (Reference 1.)

A comparison of the experimental angles of yaw at the *c. g.* with the values computed from Burgess's formula is as follows:

Run No.	$\beta$ experimental in degrees	$\beta$ computed in degrees	Difference	
			In degrees	In per cent of $\beta$ experimental
4C.....	5.89	5.57	0.32	5.4
5C.....	6.08	5.56	.52	8.5
13D.....	6.45	6.10	.35	5.4
14D.....	-6.27	-6.07	-.20	3.2
Average.....				5.6

This comparison shows that the agreement between the theoretical expression and the experimental data is within 6 per cent.

Another comparison of the observed data and theoretical calculations may be made when the equation  $\sin 2\beta = \frac{2a}{R(k_2 - k_1)}$  is reduced to an expression which defines the point of zero yaw. This expression is

$$\cot \theta = -\frac{R}{a} \frac{1}{k_2 - k_1 - b} \quad (\text{derived in Reference 12})$$

in which  $\theta$  is the angle of yaw at any point forward of the *c. g.*,  $b$  is the distance from the *c. g.* to this point, and the other quantities are as previously defined. It follows that  $\cot \theta = \infty$  defines the point of zero yaw. Therefore, when  $b = \frac{a}{k_2 - k_1}$ ,  $b$  is the distance from the *c. g.* to the point of zero yaw,  $R\beta$  of Figure 8.

For the *Los Angeles*  $a = 275$  feet and  $k_2 - k_1 = 0.9$ . Therefore,  $b = 305$  feet or 46.5 per cent  $L$  as compared with 50.5 per cent  $L$ , the average experimental value of  $R\beta$  from Table I.

The disagreement between the above values is about 8 per cent, which is slightly greater than in the former comparison of the experimental and theoretical yaw. Both of these comparisons, however, show an agreement between purely theoretical and observed characteristics that is nearly as close as the accuracy of the experimental data.

The results of these tests point out some objectionable features in the method used to determine turning characteristics which can probably be eliminated in future tests. The camera-obscura method of determining the true flight path is objectionable because it depends so much upon the accuracy of the wind-vector determination; and, furthermore, its usefulness is limited by the difficulty of making more than a small part of a turn, with a large airship, in the camera field. The recording-instrument method would be the more satisfactory means of determining the turning characteristics, providing a sufficiently sensitive and accurate turn-meter were available. The method of determining the yaw appears to be satisfactory, but should be made more accurate by refinements in the method, particularly with regard to the stabilizing and suspension of the "yaw bomb." It would also be advisable to avoid tilting the yaw camera, so that corrections for perspective would be unnecessary. Pointing the camera directly downward, however, would limit its field to a position forward of the swept-back "yaw bomb." This could be remedied by holding the "yaw bomb" forward with a drag-brace wire or by moving the camera back so that its field would include the "yaw bomb" in its swept-back positions.

The suggestion is made that in future work of this nature the air speed, yaw, and rudder angle be recorded as in these tests, and that the angular displacement be recorded by some device aboard the airship. A record of the angular velocity would be preferable, but as yet there appears to be no instrument which will record these small angular velocities accurately. The angular displacement could be recorded by the camera used to record yaw if the flights were

made over ground marked with a number of visible straight lines, such as the streets of a city, for instance. Another suggestion that has been offered is to obtain angular displacement records from a device indicating the attitude of the airship relative to the direction of the sun. This latter method would have the advantage of not limiting the field of operation to any given locality:

#### CONCLUSIONS

The results of this investigation indicate the following with regard to the turning characteristics of the *Los Angeles* and the method of determining them:

1. The radius of turn is independent of the air speed.
2. The turning coefficients compare favorably with those for other large airships.
3. The position of the point of zero yaw is independent of the rudder angle, is possibly independent of the air speed, and lies forward of the nose an average distance equal to about 6 per cent of the length of the airship.
4. The relation between radius and angle of yaw in a turn derived from Munk's airship formula is in fair agreement with the actual conditions.
5. The method of determining the turning characteristics with instruments aboard the airship is satisfactory, with the exception that a better method of determining angular velocity should be devised.

LANGLEY MEMORIAL AERONAUTICAL LABORATORY,  
NATIONAL ADVISORY COMMITTEE FOR AERONAUTICS,  
LANGLEY FIELD, VA., *April 17, 1929.*

#### REFERENCES AND BIBLIOGRAPHY

- Reference 1. DeFrance, S. J.: Flight Tests on the U. S. S. Los Angeles. I. Full Scale Pressure Distribution Investigation. N. A. C. A. Technical Report No. 324. Burgess, C. P.: Flight Tests on the U. S. S. Los Angeles. II. Full Scale Stress Measurements. N. A. C. A. Technical Report No. 325.
- Reference 2. Norton, F. H.: N. A. C. A. Recording Air-speed Meter. N. A. C. A. Technical Note No. 64, 1921.
- Reference 3. Ronan, K. M.: An Instrument for Recording the Position of Airplane Control Surfaces. N. A. C. A. Technical Note No. 154, 1923.
- Reference 4. Brown, W. G.: Synchronization of N. A. C. A. Flight Records. N. A. C. A. Technical Note No. 117, 1922.
- Reference 5. Crowley, J. W., jr., and Freeman, R. G.: Determination of the Turning Characteristics of an Airship by Means of a Camera Obscura. N. A. C. A. Technical Report No. 208, 1925.
- Reference 6. Pannell, J. R., and Frazer, R. A.: Experiments on Rigid Airship R. 33. Reports and Memoranda No. 668, 1919.
- Reference 7. Frazer, R. A., and Bateman, H.: Experiments on Rigid Airship R. 38 (ZR-2). Reports and Memoranda No. 764, 1921.
- Reference 8. Pannell, J. R., and Bell, A. H.: Experiments on Rigid Airship R. 29. Reports and Memoranda No. 675, 1920.
- Reference 9. Jones, R.: The Application of the Results of Experiments on Model Airships to Full-Scale Turning. Reports and Memoranda No. 716, 1920.
- Reference 10. Burgess, C. P.: Airship Design. Ronald Aeronautical Library. Ronald Press Co., New York, 1927.
- Reference 11. Munk, Max M.: The Aerodynamic Forces on Airship Hulls. N. A. C. A. Technical Report No. 184, 1924.
- Reference 12. Fairbanks, Karl J.: Pressure Distribution on the Nose of an Airship in Circling Flight. N. A. C. A. Technical Note No. 224, 1925.

TABLE I.—FULL-SCALE TURNING CHARACTERISTICS OF THE U. S. S. LOS ANGELES

Run No.	Time		Rudder angle in degrees	True air speed $V$ in ft./sec.	Angular velocity $\dot{\gamma}$ in rad./sec.	Turning radius $R$ in feet	Observed yaw $\beta_o$ in degrees	Computed yaw at c. g. $\beta$ in degrees	$R\beta$		Turning coefficient $K$	Length $AN$ in % $L$
	In seconds	Interval No.							In feet	In % $L$		
4C	60	3%	8	69.2	0.0214	3,235	6.5	5.2	296	45.2	9.86	1.1
	70	4%	8	68.5	.0218	3,145	7.1	5.8	319	43.7	9.59	4.6
	80	5	8	67.7	.0216	3,135	7.4	6.1	334	51.0	9.56	6.9
	90	5%	8	66.9	.0213	3,140	7.5	6.2	340	51.9	9.57	7.8
	100	6%	8	66.1	.0208	3,180	7.6	6.3	351	53.5	9.70	9.4
	110	7%	8	65.2	.0204	3,195	7.5	6.2	347	53.0	9.74	8.9
	120	7%	8	64.3	.0200	3,215	7.4	6.1	344	52.5	9.80	8.4
	130	8%	8	63.7	.0198	3,215	7.2	5.9	333	50.8	9.80	6.7
	140	8%	8	63.2	.0196	3,225	7.0	5.7	323	49.3	9.83	5.2
	150	9%	8	62.8	.0195	3,220	6.7	5.4	306	46.7	9.82	2.6
	Average						3,190		5.89		50.3	9.73
5C	50	3%	7.6	84.3	.0269	3,255	7.4	6.1	349	53.3	9.84	9.1
	60	3%	7.6	81.8	.0260	3,145	7.4	6.1	335	51.1	9.59	7.0
	70	4%	7.6	80.3	.0255	3,150	7.4	6.1	336	51.3	9.60	7.2
	80	5	7.6	78.3	.0249	3,185	7.4	6.1	341	52.0	9.71	7.9
	90	5%	7.6	78.5	.0242	3,240	7.3	6.0	342	52.2	9.88	8.1
Average						3,195		6.08		52.0	9.72	7.9
13D	80	5	12.5	69.7	.0230	3,050	7.7	6.4	340	51.9	9.33	7.8
	90	5%	12.5	68.2	.0227	3,005	7.8	6.4	338	51.6	9.16	7.5
	100	6%	12.6	66.8	.0225	2,955	7.9	6.5	336	51.3	9.01	7.2
	110	6%	13	65.9	.0223	2,930	7.9	6.5	333	50.8	8.93	6.7
	120	7%	13	65.5	.0223	2,940	7.9	6.5	335	51.1	8.96	7.0
	130	8%	13	65.2	.0222	2,940	7.8	6.4	329	50.2	8.96	6.1
Average						2,972		6.45		51.3	9.06	7.1
14D	160	10	-11.2	69.7	-.0232	3,005	-7.5	-6.1	322	49.1	9.16	5.0
	170	10%	-11.2	67.5	-.0223	2,960	-7.7	-6.3	327	49.9	9.02	5.8
	180	11%	-11.2	65.5	-.0223	2,875	-7.7	-6.3	315	48.0	8.76	4.0
	190	11%	-11.2	64.5	-.0227	2,840	-7.7	-6.3	311	47.4	8.66	3.3
	200	12%	-11.2	64.2	-.0224	2,870	-7.7	-6.3	315	48.0	8.75	4.0
	210	13%	-11.2	64.1	-.0220	2,915	-7.7	-6.3	321	49.0	8.89	4.9
Average						2,911		-6.27		48.6	8.87	4.5

NOTE.—Rudder angle, angular velocity, and yaw are considered positive in a right turn and negative in a left turn.  $AN$  is the distance from the point of zero yaw to the nose, considered positive when  $A$  is forward of the nose.